

CS 561, Randomized Data Structures :  
Hash Tables, Skip Lists, Bloom Filters,  
Count-Min sketch

Jared Saia  
University of New Mexico

# Outline

- Hash Tables
- Skip Lists
- Count-Min Sketch

# Dictionary ADT

A dictionary ADT implements the following operations

- *Insert(x)*: puts the item  $x$  into the dictionary
- *Delete(x)*: deletes the item  $x$  from the dictionary
- *IsIn(x)*: returns true iff the item  $x$  is in the dictionary

# Dictionary ADT

- Frequently, we think of the items being stored in the dictionary as *keys*
- The keys typically have *records* associated with them which are carried around with the key but not used by the ADT implementation
- Thus we can implement functions like:
  - *Insert(k,r)*: puts the item (k,r) into the dictionary if the key k is not already there, otherwise returns an error
  - *Delete(k)*: deletes the item with key k from the dictionary
  - *Lookup(k)*: returns the item (k,r) if k is in the dictionary, otherwise returns null

# Implementing Dictionaries

- The simplest way to implement a dictionary ADT is with a linked list
- Let  $l$  be a linked list data structure, assume we have the following operations defined for  $l$ 
  - $\text{head}(l)$ : returns a pointer to the head of the list
  - $\text{next}(p)$ : given a pointer  $p$  into the list, returns a pointer to the next element in the list if such exists, null otherwise
  - $\text{previous}(p)$ : given a pointer  $p$  into the list, returns a pointer to the previous element in the list if such exists, null otherwise
  - $\text{key}(p)$ : given a pointer into the list, returns the key value of that item
  - $\text{record}(p)$ : given a pointer into the list, returns the record value of that item

# At-Home Exercise

Implement a dictionary with a linked list

- Q1: Write the operation `Lookup(k)` which returns a pointer to the item with key `k` if it is in the dictionary or null otherwise
- Q2: Write the operation `Insert(k,r)`
- Q3: Write the operation `Delete(k)`
- Q4: For a dictionary with  $n$  elements, what is the runtime of all of these operations for the linked list data structure?
- Q5: Describe how you would use this dictionary ADT to count the number of occurrences of each word in an online book.

# \_\_\_\_\_ Dictionaries \_\_\_\_\_

- This linked list implementation of dictionaries is very slow
- Q: Can we do better?
- A: Yes, with hash tables, AVL trees, etc

# Hash Tables

Hash Tables implement the Dictionary ADT, namely:

- $\text{Insert}(x)$  -  $O(1)$  expected time,  $\Theta(n)$  worst case
- $\text{Lookup}(x)$  -  $O(1)$  expected time,  $\Theta(n)$  worst case
- $\text{Delete}(x)$  -  $O(1)$  expected time,  $\Theta(n)$  worst case



# Direct Addressing

- Suppose universe of keys is  $U = \{0, 1, \dots, m - 1\}$ , where  $m$  is not too large
- *Assume no two elements have the same key*
- We use an array  $T[0..m - 1]$  to store the keys
- Slot  $k$  contains the elem with key  $k$

# Direct Address Functions

```
DA-Search(T,k){ return T[k];}
```

```
DA-Insert(T,x){ T[key(x)] = x;}
```

```
DA-Delete(T,x){ T[key(x)] = NIL;}
```

Each of these operations takes  $O(1)$  time

# Direct Addressing Problem

- If universe  $U$  is large, storing the array  $T$  may be impractical
- Also much space can be wasted in  $T$  if number of objects stored is small
- Q: Can we do better?
- A: Yes we can trade time for space

# Hash Tables

- “Key” Idea: An element with key  $k$  is stored in slot  $h(k)$ , where  $h$  is a *hash function* mapping  $U$  into the set  $\{0, \dots, m-1\}$
- Main problem: Two keys can now hash to the same slot
- Q: How do we resolve this problem?
- A1: Try to prevent it by hashing keys to “random” slots and making the table large enough
- A2: Chaining
- A3: Open Addressing

# Chained Hash

In chaining, all elements that hash to the same slot are put in a linked list.

```
CH-Insert(T,x){Insert x at the head of list T[h(key(x))];}
```

```
CH-Search(T,k){search for elem with key k in list T[h(k)];}
```

```
CH-Delete(T,x){delete x from the list T[h(key(x))];}
```

## Analysis

- CH-Insert takes  $O(1)$  time if the list is doubly linked and there are no duplicate keys
- Q: How long does CH-Search and CH-Delete take?
- A: It depends. In particular, depends on the *load factor*,  $\alpha = n/m$  (i.e. average number of elems in a list)

## CH-Search Analysis

- Worst case analysis: everyone hashes to one slot so  $\Theta(n)$
- For average case, make the *simple uniform hashing* assumption: any given elem is equally likely to hash into any of the  $m$  slots, indep. of the other elems
- Let  $n_i$  be a random variable giving the length of the list at the  $i$ -th slot
- Then time to do a search for key  $k$  is  $1 + n_{h(k)}$

# CH-Search Analysis

- Q: What is  $E(n_{h(k)})$ ?
- A: We know that  $h(k)$  is uniformly distributed among  $\{0, \dots, m-1\}$
- Thus,  $E(n_{h(k)}) = \sum_{i=0}^{m-1} (1/m)n_i = n/m = \alpha$



# Hash Functions

- Want each key to be equally likely to hash to any of the  $m$  slots, independently of the other keys
- Key idea is to use the hash function to “break up” any patterns that might exist in the data
- We will always assume a key is a natural number (can e.g. easily convert strings to natural numbers)

# Division Method

- $h(k) = k \bmod m$
- Want  $m$  to be a *prime number*, which is not too close to a power of 2
- Why? Reduces collisions in the case where there is periodicity in the keys inserted

# Hash Tables Wrapup

Hash Tables implement the Dictionary ADT. Assuming  $n = O(m)$  we have:

- Insert(x) -  $O(1)$  expected time,  $\Theta(n)$  worst case
- Lookup(x) -  $O(1)$  expected time,  $\Theta(n)$  worst case
- Delete(x) -  $O(1)$  expected time,  $\Theta(n)$  worst case

# Skip List

- Enables insertions and searches for ordered keys in  $O(\log n)$  expected time
- Very elegant randomized data structure, simple to code but analysis is subtle
- They guarantee that, with high probability, all the major operations take  $O(\log n)$  time (e.g. Find-Max, Predecessor/Sucessor)
- Can even enable "find-i-th value" if store with each edge the number of elements that edge skips

# Skip List

- A skip list is basically a collection of doubly-linked lists,  $L_1, L_2, \dots, L_x$ , for some integer  $x$
- Each list has a special head and tail node, the keys of these nodes are assumed to be  $-\text{MAXNUM}$  and  $+\text{MAXNUM}$  respectively
- The keys in each list are in sorted order (non-decreasing)

# Skip List

- Every node is stored in the bottom list
- For each node in the bottom list, we flip a coin over and over until we get tails. For each heads, we make a duplicate of the node.
- The duplicates are stacked up in levels and the nodes on each level are strung together in sorted linked lists
- Each node  $v$  stores a search key ( $\text{key}(v)$ ), a pointer to its next lower copy ( $\text{down}(v)$ ), and a pointer to the next node in its level ( $\text{right}(v)$ ).

# Example

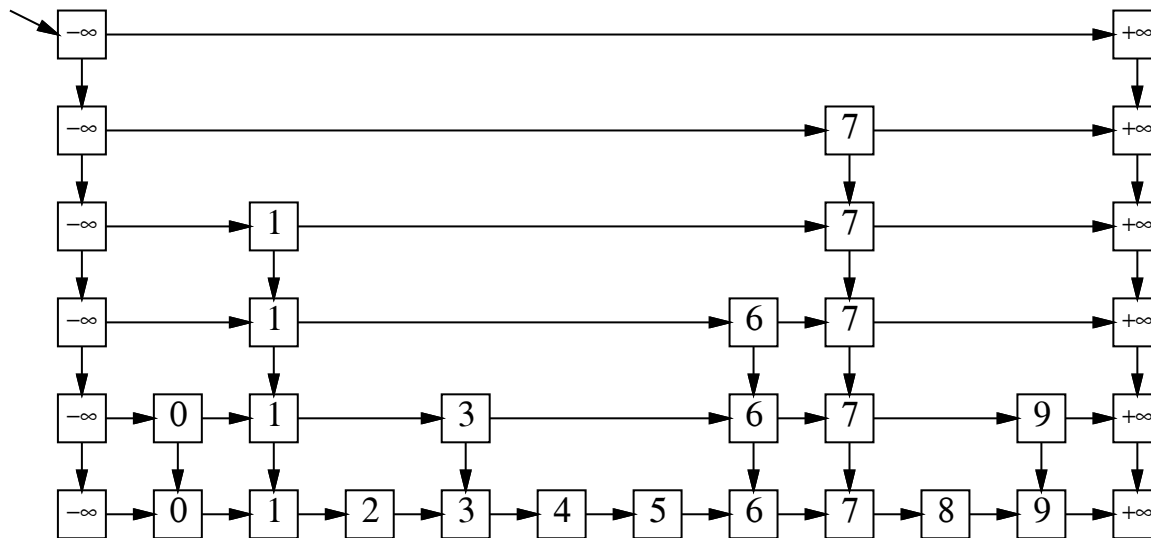

# Search

- To do a search for a key,  $x$ , we start at the leftmost node  $L$  in the highest level
- We then scan through each level as far as we can without passing the target value  $x$  and then proceed down to the next level
- The search ends either when we find the key  $x$  or fail to find  $x$  on the lowest level



# Search

```
SkipListFind(x, L){
  v = L;
  while (v != NULL) and (Key(v) != x){
    if (Key(Right(v)) > x)
      v = Down(v);
    else
      v = Right(v);
  }
  return v;
}
```

# Search Example

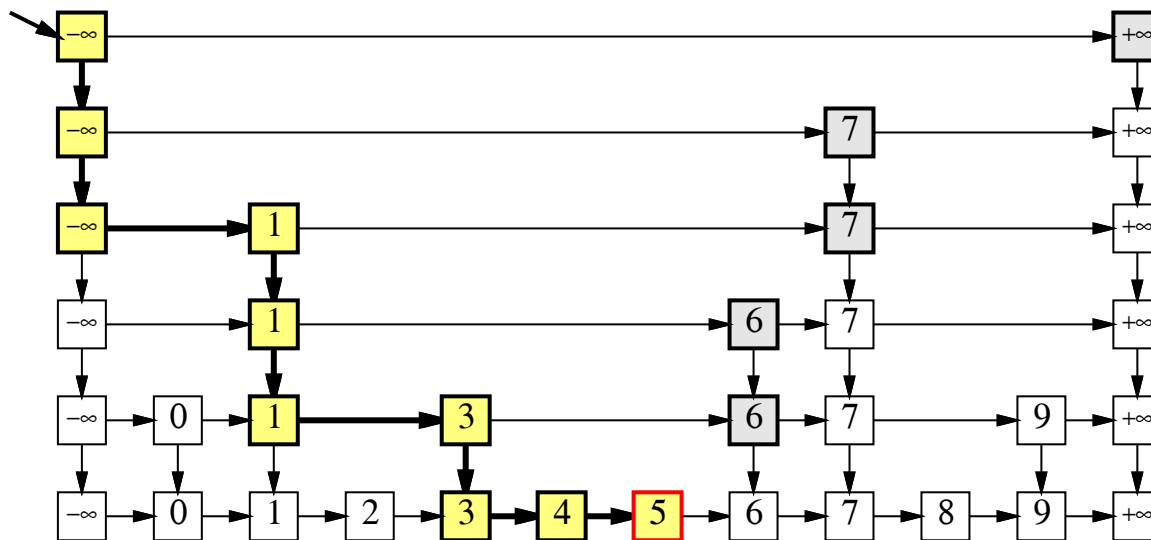

## Insert

$p$  is a constant between 0 and 1, typically  $p = 1/2$ , let `rand()` return a random value between 0 and 1

```
Insert(k){
```

```
  First call Search(k), let pLeft be the leftmost elem <= k in L_1
```

```
  Insert k in L_1, to the right of pLeft
```

```
  i = 2;
```

```
  while (rand() <= p){
```

```
    insert k in the appropriate place in L_i;
```

```
}
```

# Deletion

- Deletion is very simple
- First do a search for the key to be deleted
- Then delete that key from all the lists it appears in from the bottom up, making sure to “zip up” the lists after the deletion

# Analysis

- Intuitively, each level of the skip list has about half the number of nodes of the previous level, so we expect the total number of levels to be about  $O(\log n)$
- Similarly, each time we add another level, we cut the search time in half except for a constant overhead
- So after  $O(\log n)$  levels, we would expect a search time of  $O(\log n)$
- We will now formalize these two intuitive observations

## Height of Skip List

- For some key,  $i$ , let  $X_i$  be the maximum height of  $i$  in the skip list.
- Q: What is the probability that  $X_i \geq 2 \log n$ ?
- A: If  $p = 1/2$ , we have:

$$\begin{aligned} P(X_i \geq 2 \log n) &= \left(\frac{1}{2}\right)^{2 \log n} \\ &= \frac{1}{(2^{\log n})^2} \\ &= \frac{1}{n^2} \end{aligned}$$

- Thus the probability that a particular key  $i$  achieves height  $2 \log n$  is  $\frac{1}{n^2}$

## Height of Skip List

- Q: What is the probability that *any* key achieves height  $2 \log n$ ?
- A: We want

$$P(X_1 \geq 2 \log n \text{ or } X_2 \geq 2 \log n \text{ or } \dots \text{ or } X_n \geq 2 \log n)$$

- By a Union Bound, this probability is no more than

$$P(X_1 \geq k \log n) + P(X_2 \geq k \log n) + \dots + P(X_n \geq k \log n)$$

- Which equals:

$$\sum_{i=1}^n \frac{1}{n^2} = \frac{n}{n^2} = 1/n$$

## Height of Skip List

- This probability gets small as  $n$  gets large
- In particular, the probability of having a skip list of size exceeding  $2 \log n$  is  $o(1)$
- If an event occurs with probability  $1 - o(1)$ , we say that it occurs *with high probability*
- *Key Point:* The height of a skip list is  $O(\log n)$  with high probability.



## In-Class Exercise Trick

A trick for computing expectations of discrete positive random variables:

- Let  $X$  be a discrete r.v., that takes on values from 1 to  $n$

$$E(X) = \sum_{i=1}^n P(X \geq i)$$

Why?

$$\begin{aligned}\sum_{i=1}^n P(X \geq i) &= P(X = 1) + P(X = 2) + P(X = 3) + \dots \\ &+ P(X = 2) + P(X = 3) + P(X = 4) + \dots \\ &+ P(X = 3) + P(X = 4) + P(X = 5) + \dots \\ &+ \dots \\ &= 1 * P(X = 1) + 2 * P(X = 2) + 3 * P(X = 3) + \dots \\ &= E(X)\end{aligned}$$

## In-Class Exercise

Q: How much memory do we expect a skip list to use up?

- Let  $X_i$  be the number of lists that element  $i$  is inserted in.
- Q: What is  $P(X_i \geq 1)$ ,  $P(X_i \geq 2)$ ,  $P(X_i \geq 3)$ ?
- Q: What is  $P(X_i \geq k)$  for general  $k$ ?
- Q: What is  $E(X_i)$ ?
- Q: Let  $X = \sum_{i=1}^n X_i$ . What is  $E(X)$ ?

## Search Time

- Its easier to analyze the search time if we imagine running the search backwards
- Imagine that we start at the found node  $v$  in the bottommost list and we trace the path backwards to the top leftmost sentinel,  $L$
- This will give us the length of the search path from  $L$  to  $v$  which is the time required to do the search

# Backwards Search

```
SLFback(v){  
  while (v != L){  
    if (Up(v) != NIL)  
      v = Up(v);  
    else  
      v = Left(v);  
  }  
}
```

# Backward Search

- For every node  $v$  in the skip list  $Up(v)$  exists with probability  $1/2$ . So for purposes of analysis, SLFBack is the same as the following algorithm:

```
FlipWalk(v){
  while (v != L){
    if (COINFLIP == HEADS)
      v = Up(v);
    else
      v = Left(v);
  }
}
```

## Analysis

- For this algorithm, the expected number of heads is exactly the same as the expected number of tails
- Thus the expected run time of the algorithm is twice the expected number of upward jumps
- Since we already know that the number of upward jumps is  $O(\log n)$  with high probability, we can conclude that the expected search time is  $O(\log n)$

# Bloom Filters

- Randomized data structure for representing a set. Implementations:
- Insert(x) :
- IsMember(x) :
- Allow false positives but require very little space
- Used frequently in: Databases, networking problems, p2p networks, packet routing



# Bloom Filters

- Have  $m$  slots,  $k$  hash functions,  $n$  elements; assume hash functions are all independent
- Each slot stores 1 bit, initially all bits are 0
- Insert( $x$ ) : Set the bit in slots  $h_1(x), h_2(x), \dots, h_k(x)$  to 1
- IsMember( $x$ ) : Return yes iff the bits in  $h_1(x), h_2(x), \dots, h_k(x)$  are all 1

## Analysis Sketch

- $m$  slots,  $k$  hash functions,  $n$  elements; assume hash functions are all independent
- Then  $P(\text{fixed slot is still } 0) = (1 - 1/m)^{kn}$
- Useful fact from Taylor expansion of  $e^{-x}$ :  
 $e^{-x} - x^2/2 \leq 1 - x \leq e^{-x}$  for  $x < 1$
- Then if  $x \leq 1$

$$e^{-x}(1 - x^2) \leq 1 - x \leq e^{-x}$$

# Analysis

- Thus we have the following to good approximation.

$$\begin{aligned} Pr(\text{fixed slot is still 0}) &= (1 - 1/m)^{kn} \\ &\approx e^{-kn/m} \end{aligned}$$

- Let  $p = e^{-kn/m}$  and let  $\rho$  be the fraction of 0 bits after  $n$  elements inserted then

$$Pr(\text{false positive}) = (1 - \rho)^k \approx (1 - p)^k$$

- Where this last approximation holds because  $\rho$  is very close to  $p$  (by a Martingale argument beyond the scope of this class)

# Analysis

- Want to minimize  $(1 - p)^k$ , which is equivalent to minimizing  $g = k \ln(1 - p)$
- Trick: Note that  $g = -(m/n) \ln(p) \ln(1 - p)$
- By symmetry, this is minimized when  $p = 1/2$  or equivalently  $k = (m/n) \ln 2$
- False positive rate is then  $(1/2)^k \approx (.6185)^{m/n}$

## Tricks

- Can get the union of two sets by just taking the bitwise-or of the bit-vectors for the corresponding Bloom filters
- Can easily half the size of a bloom filter - assume size is power of 2 then just bitwise-or the first and second halves together
- Can approximate the size of the intersection of two sets - inner product of the bit vectors associated with the Bloom filters is a good approximation to this.

# Extensions

- Counting Bloom filters handle deletions: instead of storing bits, store integers in the slots. Insertion increments, deletion decrements.
- Bloomier Filters: Also allow for data to be inserted in the filter - similar functionality to hash tables but less space, and the possibility of false positives.

# Data Streams

- A router forwards packets through a network
- A natural question for an administrator to ask is: what is the list of substrings of a fixed length that have passed through the router more than a predetermined threshold number of times
- This would be a natural way to try to, for example, identify worms and spam
- Problem: the number of packets passing through the router is \*much\* too high to be able to store counts for every substring that is seen!

# Data Streams

- This problem motivates the data stream model
- Informally: there is a stream of data given as input to the algorithm
- The algorithm can take at most one pass over this data and must process it sequentially
- The memory available to the algorithm is much less than the size of the stream
- In general, we won't be able to solve problems exactly in this model, only approximate



# Our Problem

- We are presented with a stream of items  $i$
- We want to get a good approximation to the value  $\text{Count}(i, T)$ , which is the number of times we have seen item  $i$  up to time  $T$

# Count-Min Sketch

- Our solution will be to use a data structure called a *Count-Min Sketch*
- This is a randomized data structure that will keep approximate values of  $\text{Count}(i, T)$
- It is implemented using  $k$  hash functions and  $m$  counters

# Count-Min Sketch

- Think of our  $m$  counters as being in a 2-dimensional array, with  $m/k$  counters per row and  $k$  rows
- Let  $C_{a,b}$  be the counter in row  $a$  and column  $b$
- Our hash functions map items from the universe into counters
- In particular, hash function  $h_a$  maps item  $i$  to counter  $C_{a,h_a(i)}$

# Updates

- Initially all counters are set to 0
- When we see item  $i$  in the data stream we do the following
- For each  $1 \leq a \leq k$ , increment  $C_{a, h_a(i)}$

# Count Approximations

- Let  $C_{a,b}(T)$  be the value of the counter  $C_{a,b}$  after processing  $T$  tuples
- We approximate  $\text{Count}(i,T)$  by returning the value of the *smallest* counter associated with  $i$
- Let  $m(i,T)$  be this value

# Analysis

Main Theorem:

- For any item  $i$ ,  $m(i, T) \geq \text{Count}(i, T)$
- With probability at least  $1 - e^{-m\epsilon/e}$  the following holds:  
 $m(i, T) \leq \text{Count}(i, T) + \epsilon T$

## Proof

- Easy to see that  $m(i, T) \geq \text{Count}(i, T)$ , since each counter  $C_{a, h_a(i)}$  incremented by  $c_t$  every time pair  $(i, c_t)$  is seen
- Hard Part: Showing  $m(i, T) \leq \text{Count}(i, T) + \epsilon T$ .
- To see this, we will first consider the specific counter  $C_{1, h_1(i)}$  and then use symmetry.

## Proof

- Let  $Z_1$  be a random variable giving the amount the counter is incremented by items other than  $i$
- Let  $X_t$  be an indicator r.v. that is 1 if  $j$  is the  $t$ -th item, and  $j \neq i$  and  $h_1(i) = h_1(j)$
- Then  $Z_1 = \sum_{t=1}^T X_t$
- But if the hash functions are “good”, then if  $i \neq j$ ,  $Pr(h_1(i) = h_1(j)) \leq k/m$  (specifically, we need the hash functions to come from a 2-universal family, but we won’t get into that in this class)
- Hence,  $E(X_t) \leq k/m$



## Proof

- Thus, by linearity of expectation, we have that:

$$E(Z_1) = \sum_{t=1}^T (k/m) \quad (1)$$

$$\leq Tk/m \quad (2)$$

- We now need to make use of a very important inequality:  
Markov's inequality

# Markov's Inequality

- Let  $X$  be a random variable that only takes on non-negative values
- Then for any  $\lambda > 0$ :

$$Pr(X \geq \lambda) \leq E(X)/\lambda$$

- Proof of Markov's: Assume instead that there exists a  $\lambda$  such that  $Pr(X \geq \lambda)$  was actually larger than  $E(X)/\lambda$
- But then the expected value of  $X$  would be at least  $\lambda * Pr(X \geq \lambda) > E(X)$ , which is a contradiction!!!

## Proof

- Now, by Markov's inequality,

$$Pr(Z_1 \geq \epsilon T) \leq (Tk/m)/(\epsilon T) = k/(m\epsilon)$$

- This is the event where  $Z_1$  is “bad” for item  $i$ .

## Proof (Cont'd)

- Now again assume our  $k$  hash functions are “good” in the sense that they are independent
- Then we have that

$$\prod_{i=1}^k \Pr(Z_j \geq \epsilon T) \leq \left(\frac{k}{m\epsilon}\right)^k$$

## Proof

- Finally, we want to choose a  $k$  that minimizes this probability
- Using calculus, we can see that the probability is minimized when  $k = m\epsilon/e$ , in which case

$$\left(\frac{k}{m\epsilon}\right)^k = e^{-m\epsilon/e}$$

- This completes the proof!

## Recap

- Our Count-Min Sketch is very good at giving estimating counts of items with very little external space
- Tradeoff is that it only provides approximate counts, but we can bound the approximation!
- Note: Can use the Count-Min Sketch to keep track of all the items in the stream that occur more than a given threshold (“heavy hitters”)
- Basic idea is to store an item in a list of “heavy hitters” if its count estimate ever exceeds some given threshold